

AUTO-ID & COMMUNICATION EXPO 2022

Show Brochure

2022.9.14^{WED} - 16^{FRI} TOKYO BIG SIGHT



A BRIGHTER FUTURE WITH AUTO-ID

未来をつなぐ **AUTO-ID**

— SDGsとDXに貢献 —



www.autoid-expo.com

Sponser : Japan Automatic Identification Systems Association



Show Office : CNT Inc.

4F, 1-24-3, Kanda Suda-cho, Chiyoda-ku, Tokyo 101-0041, JAPAN

TEL.+81-3-5297-8855 FAX.+81-3-5294-0909

E-mail : info_en@autoid-expo.com

CONTENTS

GENERAL INFORMATION.....	1
AUTO-ID COMMUNICATION EXPO PLOFILE	2
BOOTH SIZE AND CHARGES “Type A”	3
BOOTH SIZE AND CHARGES “Type B (Low-priced, Small size)”	4
Mobile & Wearable Zone.....	5
Imaging Zone	6
HOW TO EXHIBIT	7
OFFICIAL ADVERTISEMENTS	8
ADMINISTRATION.....	9
REPORT OF LAST EXHIBITION	10

AUTOID & COMMUNICATION EXPO 2022

~ A BRIGHTER FUTURE WITH AUTO-ID ~

GENERAL INFORMATION

Title	AUTO-ID & COMMUNICATION EXPO 2022
Show Period	September 14 (Wed) - 16 (Fri) , 2022 10:00 - 17:00
Venue	TOKYO BIG SIGHT(Tokyo International Exhibition Center), West Hall 3-11-1, Ariake, Koto-ku, Tokyo 135-0065 Japan Tel: +81-3-5530-1111
Admission Fee	¥1,000 (Free entrance for visitors with invitation tickets.)
Sponsor	Japan Automatic Identification Systems Association FK Bldg.7F, 1-9-5, Iwamoto-cho, Chiyoda-ku, Tokyo 101-0032, Japan Tel:+81-3-5825-6651 Fax:+81-3-5825-6653 https://www.jaisa.or.jp
Supporting Organizations (Planned)	Ministry of Internal Affairs and Communications Ministry of Economy, Trade and Industry and others
Special Cooperation	SANKEI SHIMBUN CO.,LTD.
Cooperating Organization	Approx.30 relevant organizations
Special Exhibit Zone	Mobile & Wearable Zone An exhibit zone for Mobile and Wearable Devices. Imaging Zone An exhibit zone Featuring State-of-the-Art Applications of Image Identification Technology
Concurrent Programs	AUTO-ID Seminar, Business & Technology SPICE (language Japanese only) September 14 (Wed) - 16 (Fri)
Show Office	CNT Inc. Attn: (Mr.) M. Tanaka 4F, 1-24-3 Kanda Suda-cho, Chiyoda-ku, Tokyo 101-0041, Japan Tel: +81-3-5297-8855 Fax: +81-3-5294-0909 E-mail: info_en@autoid-expo.com

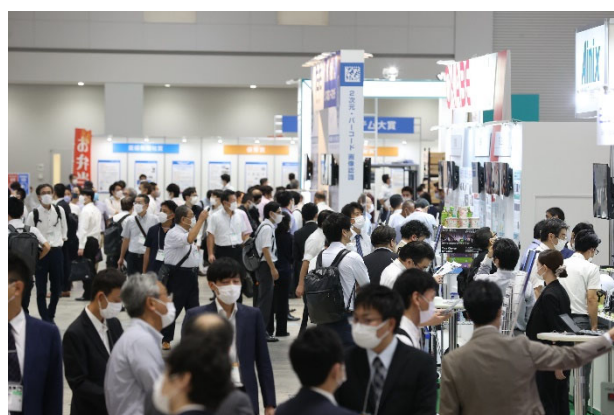
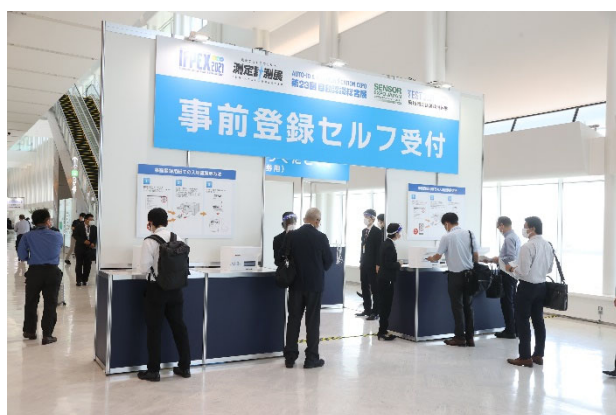

AUTO-ID COMMUNICATION EXPO PROFILE

The only exhibition in Japan devoted exclusively to cutting-edge automatic identification products, technologies and solutions.

Exhibit Categories

- Automatic identification products and technologies
Bar codes and Two-dimensional symbols, GS1 DataBar, RFID, NFC, Cards (IC, magnetic, optical, etc.), OCR, Biometrics, Image recognition
- Solutions using automatic identification
All solutions that take advantage of automatic identification, such as production support systems, distribution and logistics systems, retail and wholesale support systems, traceability, Supply Chain Management (SCM), event and amusement support systems, Customer Relationship Management (CRM), security systems, medical, education, library, transportation (rail, air, harbor, etc.), finance, disaster control, other public service support systems
- Middleware platform, encryption technologies, image processing

Zone Dedicated to Automatic Identification Technology, a Must in the IoT!

- Mobile & Wearable Zone
This zone features mobile terminals, mobile-connected devices, wearables, and the like.
- Imaging Zone
This zone features imaging, the ultimate in automatic identification technology – including individual pattern identification using image identification technology (image processing, 3D measurement), barcode identification using image processing, and character recognition (OCR).

A merit to exhibit this Trade Show!

- Automatic identification solutions can be offered to users.
Many users from industries such as manufacturing, distribution, logistics, retailing, and public services will attend this exhibition seeking efficient, safe, and reliable automatic identification solutions.
- Many system integrators and vendors will attend, seeking cutting-edge equipment and technologies.
Because many system integrators and related vendors will attend this exhibition, it will be a great opportunity to expand your business and sales channels.
- The exhibition will be a place for integration and collaboration with automatic identification related businesses.
This exhibition will be a great opportunity for collaboration between businesses and the acquisition of business partners, as cutting-edge equipment and products, solutions, and services related to automatic identification will be exhibited under the same roof, and many system integrators and vendors will be attending

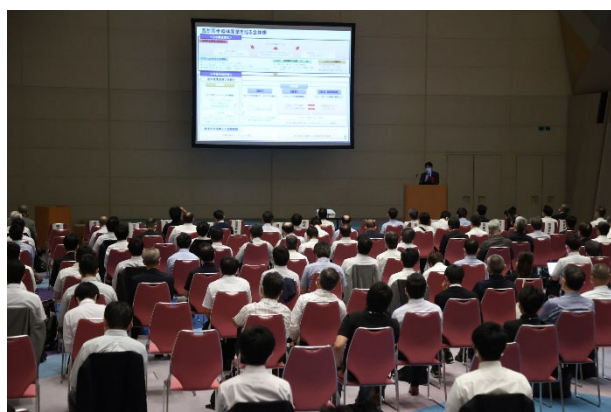

AUTO-ID & COMMUNICATION EXPO 2022

~ A BRIGHTER FUTURE WITH AUTO-ID ~

BOOTH SIZE AND CHARGES “Type A”

Minimum booth Unit (size) : 2.97m(W)×2.97m(D)×2.7m(H)

Participation fee per minimum booth unit :

Number of booths	Exhibition Fee (Cost per booth including consumption tax)	
	JAISA members	Non-members
1 to 2 booths	429,000 yen	484,000 yen
3 to 7 booths	385,000 yen	440,000 yen
8 to 12 booths	341,000 yen	396,000 yen
13 to 15 booths	330,000 yen	385,000 yen
16 to 24 booths	319,000 yen	374,000 yen
25 booths or more	297,000 yen	352,000 yen

(JPY, Consumption tax included)

The exhibition fees include: exhibition space -- width: 2.97 m × depth 2.97 m -- walls

Explanation of Booth Layout

Layout of booths is to be chosen from alternatives shown on the below.

- Minimum 4 units of booth are required to form “Block” type layout.
- Minimum 8 units of booth are required to form “Island” type layout.
- The maximum number of booth allowed to form “Row” type layout is 5

1 to 5 booths in a Row type

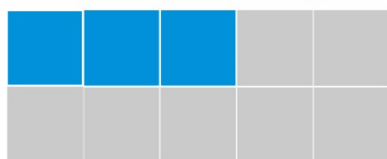

4 block type booths

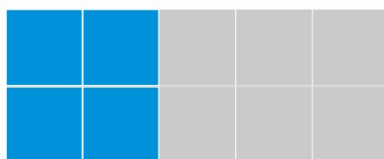

8 Island type booths

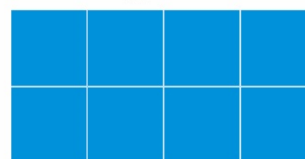

On height restrictions for decorations

*Row type booth(s)

*Block type booth(s)

Decorations are permitted to a maximum height of 2.7 m for areas within 1 m of adjacent booths, rear walls and access aisles, while the maximum height for any areas other than these is 3.6m.

*Row type booth(s)

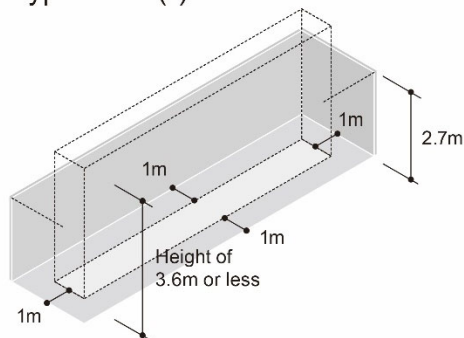

*Block type booth(s)

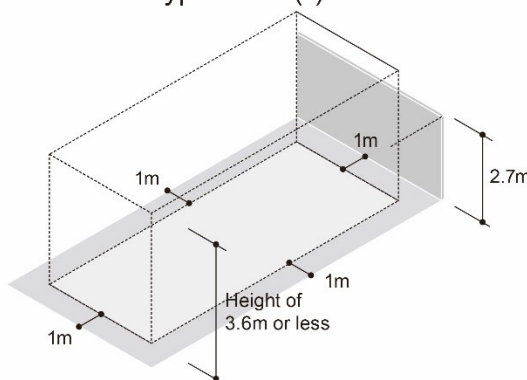

*” Island” type booth(s)

Decoration is permitted up to a maximum height of 5.0m.

BOOTH SIZE AND CHARGES “Type B (Low-priced, Small size)”

Minimum booth Unit (size) : 1.98m(W)×1.98m(D)×2.7m(H)

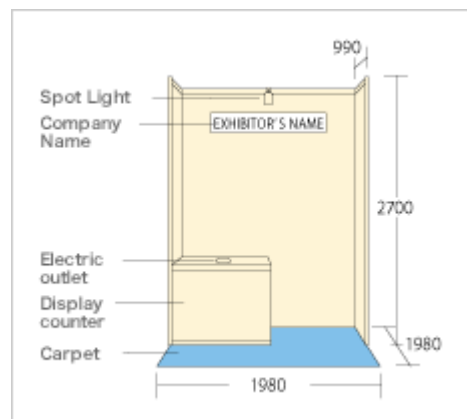

Participation fee per minimum booth unit :

Number of booth	Exhibition Fee (Cost per booth including consumption tax)	
	JAISA Members:	Non-JAISA Members:
1 to 2 booths	231,000 yen	264,000 yen

The exhibition fees include:

exhibition space -- width: 1.98 m × depth 1.98 m -- walls (rear and side, 1 m); company nameplate; carpet;
 exhibition stand--width: 1.0 m × depth 1.0 m × height: 0.8 m -- spotlight: 100W × 1; electrical outlets (100V with ground) —one set of two outlets; installation costs for electrical lines up to 500W; electricity costs.

* Additional charges apply for requests of additional equipment. Detailed materials will be distributed at the orientation for exhibitors.

* Please be aware that even when the basic display mentioned above is not used, deductions from the exhibition fee cannot be made.

On height restrictions for decorations

The maximum standard height is 2.7 m.

Exhibition conditions

- Up to two booths per company
- Cannot be exhibited together with Type A exhibition specifications
- Presentations using equipment such as microphones and speakers cannot be given in the booths.
- The locations of the booths are not determined by lottery, but rather at the discretion of the host.

AUTO-ID & COMMUNICATION EXPO 2022

~ A BRIGHTER FUTURE WITH AUTO-ID ~

Mobile & Wearable Zone

An exhibit zone Features mobile terminals, mobile-connected devices, wearables, and the like.

These days, it is no longer unusual to find mobile terminals in manufacturing, transportation, logistics, retail, and other sites. What's more, much attention has been focused recently on wearable devices worn to improve the efficiency of work.

The AUTOID & COMMUNICATION EXPO has introduced a zone dedicated to mobile terminals, mobile-connected devices, wearables, and the like.

Please consider exhibiting in the "Mobile & Wearable Zone" this year.



Exhibit Categories

- **Mobile devices/accessories**
Readers/writers, printers, business PDAs, POS, tablets, smartphones, medical devices, etc.
- **Wearable devices**
Glasses, watches, rings, etc.
- **Software/apps**
ales support software/apps, inventory management software/apps, sales management software/apps, manufacturing process management software/apps, other support software/apps, etc.
- **Embedded devices, middleware, transmission-related services**

Exhibition fees and exhibition unit specifications

Applied in accordance with type A or type B of the AUTO-ID & COMMUNICATION EXPO.

Imaging Zone

An exhibit zone Featuring State-of-the-Art Applications of Image Recognition Technology

With the rapid spread of cell phones and smartphones with cameras, it is no exaggeration to say that we're now living in an era when everyone owns and uses their own personal image identification tool. And these tools have still further potential, not just for expanded use in manufacturing processes and security applications, but also for more personal use in everyday life, access to information, and the like.

This zone brings together various examples of advanced image identification technology including applied technologies for corporate and personal use, with a focus on individual pattern identification using image identification technology (image processing, 3D measurement); image information identification by image processing and barcode identification; character recognition (OCR); fingerprint and face authentication; and so forth.

Exhibit Categories

- **Image input devices**

Various cameras, image input boards, lighting equipment for image input, and more

- **Image processing devices**

Various image processing devices, image analysis systems, image processing boards, and more

- **Software**

Inspection software, measurement software, analysis software, barcode reading software, and more

- **Systems**

Face/fingerprint authentication systems, next-generation OCR systems (character recognition), augmented reality (AR) systems, abnormal behavior detection systems, and more

Exhibition fees and exhibition unit specifications

Applied in accordance with type A or type B of the AUTO-ID & COMMUNICATION Expo.

AUTO-ID & COMMUNICATION EXPO 2022

~ A BRIGHTER FUTURE WITH AUTO-ID ~

HOW TO EXHIBIT

Application

Please fill in the attached “application form for exhibit” and send it to the Show Office.

Application Deadline

May 31, 2022

(The application will be closed as soon as all the booths are booked.)

Booth assignment

The booth assignment will be decided by open lot at exhibitor’s explanatory meeting on Beginning of July. If it is impossible to attend the meeting, the organizer draws lots instead of them.

Payment

On receipt of the application form, invoice will be issued by the Show Office.

Please make remittance in Japanese Yen to the designated bank account by July 29 (Fri.), 2022. In the event of the exhibitor failing to pay the participation fee by the deadline (July 29, 2022), an exhibition booth cannot be reserved. The payment of the participation fee must be made in Japanese Yen, and all commissions concerning the bank transfer are also charged to the exhibitor.

Cancellation

As a principle, no cancellation is accepted. The organizer, however, may accept the cancellation if there should be right reason to accept with the following cancellation fee.

June 1 - June 30, 2022 : 50% participation fee
After July 1, 2022 : 100% participation fee

Schedule

May 31, 2022 (Fri)	Application for AUTO-ID & COMMUNICATION EXPO Deadline
July 29, 2022(Fri)	Remittance deadline
Beginning of July	Exhibitor’s explanatory meeting, Booth assignment open lot(in Tokyo)
Beginning of August	Sending of the Exhibiter badge & Invitation Tickets
September 12 & 13, 2022	Move-in / Set-up day
September 16, 2022	Move-out / Dismantle day

OFFICIAL ADVERTISEMENTS

Advertisements on the Official Site

We will post the AUTO-ID Communication Expo official website from the end of March to the end of October. A wealth of information is posted at the official website, including detailed information on the Expo and exhibit information from exhibitors, as well as numerous speeches every year from relevant people in the industry.

Please use the following advertising plan, which is set for the official site from this year going forward. The plan provides the opportunity for you to effectively promote your company prior to the time of the Expo in order to draw visitors to your booth.

You can run banner advertisements and menu bar advertisements at the official homepage for the 24th AUTOID Communication Expo.

《Requirements for Application》

- Deadline for Application: July 22 (Fri), 2022
- * The application period ends if all time slots are filled

		① Header banner	② Bar
Image Size		100 pixels (height) × 200 pixels (length)	40 pixels (height) × 150 pixels (length)
File Format	GIF	○	○
	Animated GIF	○	○
Fee for Posting / per month(with tax)		44,000 yen	22,000 yen
Number of Applications		3	4
Term of Posting		Scheduled for: 1 March 2022—31 October 2022	



E-Mail News with Five-Column Ads

At AUTO-ID COMMUNICATION Expo, E-Mail News bulletins are scheduled to be sent multiple times to the mailing list (approximately 90,000 past Expo visitors.)

《Requirements for Application》

- Deadline for application: Please refer to the figure to the below
- * The application period ends if all time slots are filled.
- Number of Applications: One for each mail.
- Method of Submission: As data
- Size of Draft: Body text (70 characters x five lines)
- Fee for posting: 33,000 yen (with tax)

Time frame	Topics	Time to send	Deadline for applications
①	Seminar Overview Posted	End of July	June 16
②	Latest Information Posted	Beginning of August	June 16
③	Warmly Welcoming Seminars	Middle of August	July 27
④	Opening Next Week!	September 5	July 27
⑤	Seminar Deadline Tomorrow	September 7	July 27
⑥	Opening Tomorrow	September 13	July 27
⑦	Held until Tomorrow	September 15	July 27

AUTO-ID & COMMUNICATION EXPO 2022

~ A BRIGHTER FUTURE WITH AUTO-ID ~

ADMINISTRATION

The following facilities will be provided at the show site for the convenience of exhibitors and visitors as well as for the management of the show.

Secretariat Office The Secretariat office will be set up at the show site from 8:00 , September 12 (Mon) to 22:00, September 16 (Fri).

TOKYO BIG SIGHT(Tokyo International Exhibition Center), West Hall 4
3-11-1, Koto-ku, Ariake, Tokyo 135-0063 Japan
Secretariat of 「AUTO-ID & COMMUNICATION EXPO 2022」

Registration Counter

The Registration Counter will be set up in front of the exhibition site, where visitor registration and information service will be rendered.

Lounge

Lounge will be provided inside the exhibition site as a space for exhibitors to have business talks with visitors.

Prepaid card for Restaurants

Prepaid card system is available at the exhibition site. Instead of cash payment, you can use the prepaid card at the restaurants. The prepaid card is sold at the 「Service corner」at TOKYO BIG SIGHT Entrance Hall 2F.

Facilities of the Exhibition Hall

West 4 Hall (Plan)

Floor space	: 6,840 m ²
Hall Illuminance	: 500 lux
Ceiling height	: 13~18m
Air-conditioning	: Available
Floor load	: 5t/m ²
Cargo entrance	: H6.0m×W8.0m
Meeting rooms	: We will set up inside the exhibition Hall
Restaurants and shops	: About 20 shops

REPORT OF LAST EXHIBITION

AUTO-ID EXPO 2021

Show Period : October 6 (Wed.) — 8 (Fri.), 2021 10:00-17:00
Venue : TOKYO BIG SIGHT(Tokyo International Exhibition Center) South Hall 4
Number of Exhibitors and Booths : 55 corporations and organization, at 163 booths
Total Number of Visitors : 6,994
Admission Fee : ¥1,000
Sponsor : Japan Automatic Identification Systems Association (JAISA)
Supporting Organizations : Ministry of Internal Affairs and Communication
Ministry of Foreign Affairs
Ministry of Economy, Trade and Industry
Special Cooperation : SANKEI SHIMBUN CO.,LTD.
Cooperating Organization : Approx.34 relevant organizations
Seminar : AUID-ID Seminar, Business & Technology SPICE
October 6 (Wed.) - 8 (Fri.),
South Conference Room (South Hall 2F)

Exhibitors List 2021

AUTOID & COMMUNICATION EXPO

AINIX Corp. / Autonics Co., Ltd. / COMSYS JOHO SYSTEM CORP. / DAIDO CORP. / Duplo Co., Ltd. / EFTECT Co., Ltd. / Fujikura Dia Cable Ltd. / General Co., Ltd. / GIT Japan Inc. / GRAPE SYSTEMS INC. / GS1 Japan / Hakuto Co., Ltd. / HAYATO Information Co., Ltd. / Hitachi High-Tech Nexus Corp. / Imager Co., Ltd. / JAPAN INDUSTRIAL PUBLISHING CO., LTD. / KISCO LTD. , Uni Tag Ltd. / MARS TOHKEN SOLUTION CO. LTD. / MASPRO DENKOH CORP. / Midoriya Information Systems Co., Ltd / NIHON MICRON Co., Ltd. / NIKKEI INC. / Okabe Marking Systems Co., Ltd. / Ondemand Laboratory Co., Ltd. / PHOENIX CO., LTD. / RFID Alliance , Alien Technology , Datamars , RFcampEN CO., LTD. / RYUTU JOHO RABERUSHA / SATO CORP. / SilenceNet, Inc. , Nihon Mechatronics Co., Ltd. / S.R. CO.,LTD. / SystemGear Co.,Ltd. / TAKAYA Corp. / Telepower Inc. / Terrara Code Research Institute, Inc. / TOPPAN INC. / TOSHIBA TEC CORP. / WOM SYSTEM DESIGN Co., Ltd , SACOS CORP.

Mobile & Wearable Zone

AIMEX Corp. / Gazo Co., Ltd.

Imaging Zone

GRAPE SYSTEMS INC. / COMSYS JOHO SYSTEM CORP. / SHIFT Ltd. , Info Farm co., Ltd. / Duplo Co., Ltd. / TOME R&D Inc. / Trust Technology Co., Ltd.